

REVISIONS					
REV.	DATE	ECN #	DESCRIPTION	BY	APP'D

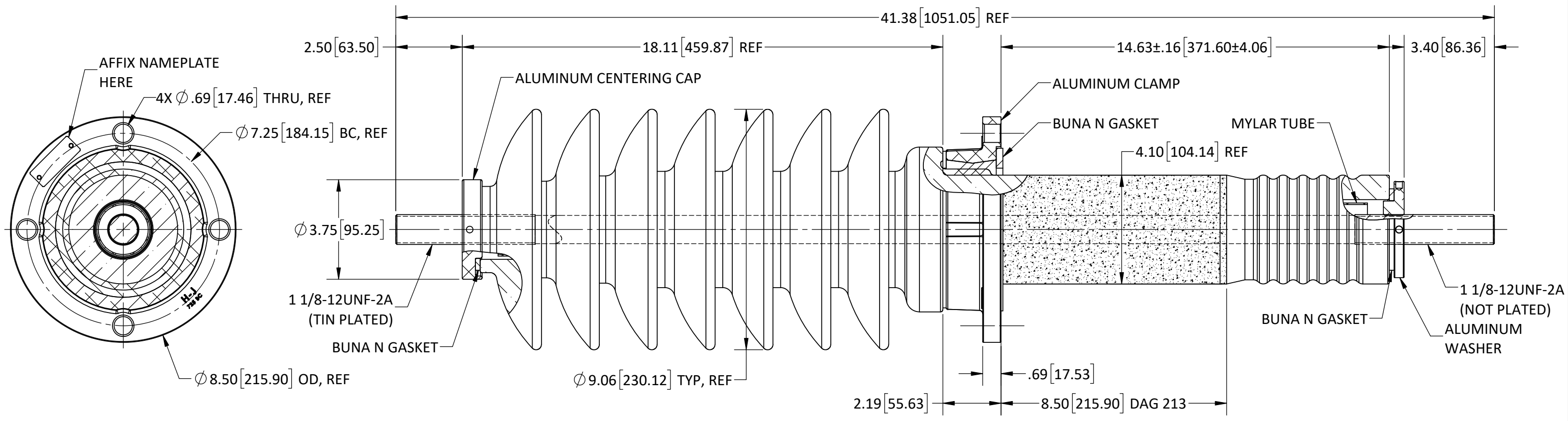

MOUNTING HOLE NOTE:

1. FOUR (4) ϕ .688[17.46] THRU HOLES EQUALLY SPACED 90°.
2. LOCATED ON A ϕ 7.25[184.15] BC ON THE ALUMINUM CLAMP.

MATERIAL:

STUD - COPPER C11000 (TIN PLATED PER DRAWING)
 OIL - TYPE 2 TRANSFORMER OIL

NOTES:

1. SHANK TO FIT INTO ϕ 4-1/2" TANK HOLE.
2. FOR VERTICAL MOUNTING.
3. MIN COLD OIL LEVEL : 4" UP SHANK.

PORCELAIN NOTES:

1. WET PROCESS ELECTRICAL PORCELAIN.
2. GREY GLAZE MUNSELL 5BG 7.0/0.4
3. TOLERANCE \pm 3% WITH NOTHING LESS THAN \pm .03".
 UNLESS OTHERWISE NOTED ON THE DRAWING

SPECIFICATIONS:

1. VOLTAGE RATING.....46kV CLASS
2. BASIC IMPLUSE LEVEL.....250kV BIL
3. NOMINAL CURRENT RATING.....994 AMPS @ 1000A /SQ-IN
4. CREEP DISTANCE (MIN).....42.50"[1079.50]
5. STRIKE DISTANCE (MIN).....18.75"[476.25]
6. APPROXIMATE WEIGHT.....67.60 LBS

	TOLERANCES <small>(EXCEPT AS NOTED) DIMENSIONS ARE SHOWN IN: in/mm</small>		H - J ENTERPRISES, INC. 3010 HIGH RIDGE BLVD. HIGH RIDGE, MO. 63049 USA PHONE 1-636-677-3421 FAX 1-636-376-1915	
	DECIMAL .X = \pm .10/2.54mm .XX = \pm .06/1.52mm .XXX = \pm .03/.76mm FRACTIONAL \pm		46 kV CLASS POWER BUSHING	MATERIAL (SEE DRAWING)
PROPRIETARY AND CONFIDENTIAL <small>THE INFORMATION CONTAINED IN THIS DRAWING IS THE SOLE PROPERTY OF H-J ENTERPRISES, INC. ANY REPRODUCTION IN PART OR AS A WHOLE WITHOUT THE WRITTEN PERMISSION OF H-J ENTERPRISES, INC. IS PROHIBITED.</small>	ANGULAR \pm 2°	DRAWN BY T J F	DATE 12/11/2019	SCALE N.T.S.
REMOVE ALL BURRS & SHARP EDGES				AS1768-0011